

LUMI

A white wolf is the central focus, standing in a futuristic, blue-toned digital environment. The background is filled with vertical lines, data points, and a grid-like pattern, suggesting a high-tech or computational setting. The overall aesthetic is clean and modern, with a strong emphasis on the color blue.

**How do you build a flagship
supercomputer, and why would
you like to do that?**

Dr. Pekka Manninen
Director, Science and Technology
Advanced Computing Facility
CSC – IT Center for Science, Finland

Outline



The story of LUMI (briefly)



LUMI's technical architecture



First scientific showcases of LUMI

LUMI Consortium

- Unique consortium of 10 countries with strong national HPC centers
- The resources of LUMI will be allocated per the investments
- The share of the EuroHPC JU (50%) will be allocated by a peer-review process and available for all European researchers
- The shares of the LUMI partner countries will be allocated by local considerations and policies – seen and handled as extensions to national resources



LUMI Datacenter in Kajaani

100% hydroelectric energy up to 200 MW

Very reliable power grid

100% free cooling available, PUE 1.03

Waste heat reuse in district heating leads to thousands of tons CO₂ reduced every year and considerable financial savings

Extreme connectivity: Kajaani DC is a direct part of the Nordic backbone. 4x100 Gbit/s to GÉANT in place, can be easily scaled up to multi-terabit level

Elevated security standards guaranteed by ISO27001 compliancy





LUMI timeline

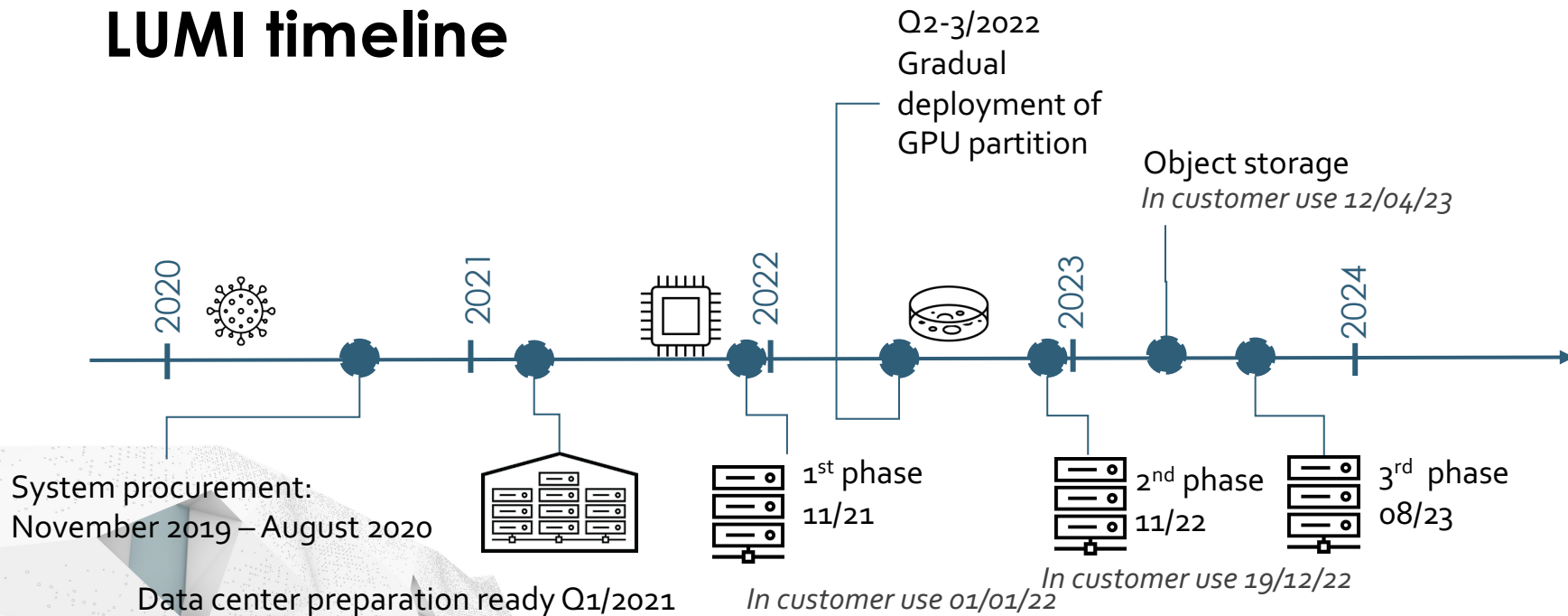

Technical Architecture

LUMI: one of the fastest supercomputers in the world

- LUMI is an **HPE Cray EX** supercomputer manufactured by **Hewlett Packard Enterprise**
- HPL performance over **375 petaflop/s** makes the system one of the world's fastest
 - #3 in Top500 (#1 in Europe)
 - #3 HPCG, #2 HPL-MxP



1 system

375
Pflop/s

Sustained performance

Computing power
equivalent to

1 500 000

Modern laptop computers

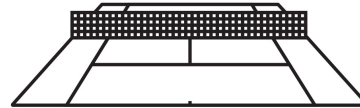

Size of two tennis
courts

Modern platform for

High-performance
computing,
Artificial intelligence,
Data analytics

Based on GPU technology

LUMI, the Queen of the North

LUMI is a Tier-0 GPU-accelerated supercomputer that enables the convergence of high-performance computing, artificial intelligence, and high-performance data analytics.

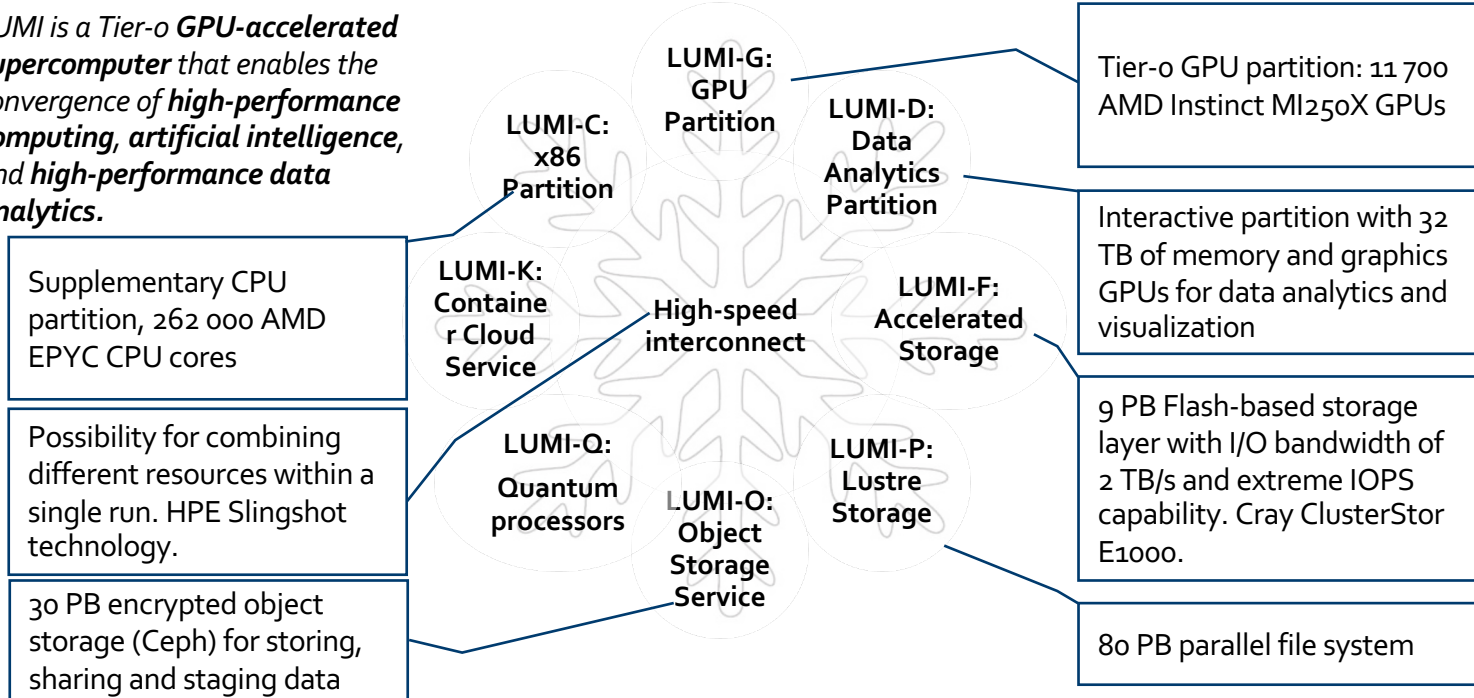

LUMI compute node configurations

LUMI-G

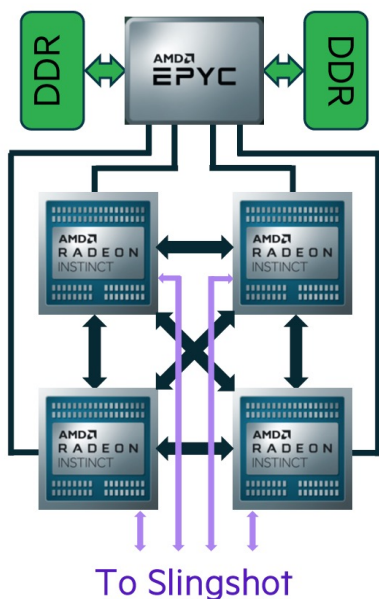

2928 nodes with 4 x MI250X + 1 x AMD Trento processor, 512 GB host memory and 512 GB device memory (HBM2)
4 x 200 Gbit/s NIC
Infinity Fabric

2x 64-core AMD Milan processors per node
1888 nodes with 256 GB, 128 with 512 GB and 32 with 1 TB
1 x 200 Gbit/s NIC

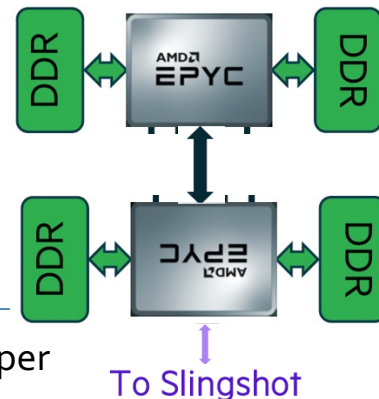

LUMI-C

Enhanced user experience

- High-level interfaces on LUMI: Jupyter Notebooks, Rstudio and such to back-end to LUMI compute nodes (09/23)
- A rich stack of pre-installed software
- Datasets as a Service: curated large reference datasets made available and maintained
- Inference service for large ML models trained on LUMI (12/23)
- Support for handling data needing elevated security (GDPR subjected, IP-closed, etc) (12/23)

Early Scientific Showcases

Enabler of world-class scientific breakthroughs

LUMI is designed as a 'Swiss army knife' targeted for **a wide spectrum of use cases and user communities.**

- **Climate research:** More precise climate models and the interconnection of different climate models – digital twins of Earth [ICON](#)
- **Data science:** analyzing and re-analyzing large data sets (simulated and measured) e.g. in atmospheric science, environmental science, climate modelling, material science and linguistics.
- **Plasma physics:** Predicting and preparing for the societal effects of extreme space weather events. Multi-scale modeling of fusion reactors. [Vlasiator](#), [GENE](#)
- **Life sciences:** enabling calculation of protein function, structural protein-protein interactions. [Gromacs](#)
- **Materials science:** quantum-mechanical simulations with global impact are development of better energy storage materials, more efficient solar cells, and better catalyst materials. [CP2K](#), [GPAW](#)
- **Humanities and social sciences:** Natural language processing, large language models. Large-scale data analytics from social networks and the modelling of complex societal phenomena.
- Fast-track for **urgent computing** needs in time- and mission-critical simulations, e.g. related to national or EU security, or other major crisis e.g. pandemic.

Early Showcases: Large Language Models and Generative AI

- **Objective: Democratization of generative AI**
- Several ongoing LUMI projects to train large language models of various European languages
 - Finnish, Swedish, Norwegian, Estonian, English,...
- One pilot project of LUMI pre-trained a 13B parameter GPT-3 and a 176B parameter Bloom model – by far the largest language model of Finnish to date
 - Exhausting all digital material in Finnish
- We are working on to provide an API for instructional LLM and open-source foundational LLMs



<https://www.lumi-supercomputer.eu/research-group-created-the-largest-finnish-language-model-ever-with-the-lumi-supercomputer/>

Early Showcases: Climate Adaptation Digital Twin

- **Objective: To build a digital twin of Earth's climate to understand the impacts of climate change and help in making data-driven political decisions in their mitigation**
- Global climate simulations with two ESMs (ICON and IFS-FESOM/NEMO) at an unprecedented resolution (~5 – 10 km) over multiple decades.
- Six prototype impact models: Wind energy, river floods, fresh water availability, urban heat waves, wild fire risk and emissions
- With a novel approach, output of ESMs will be streamed to a set of applications, including impact models
 - timely delivery of climate information to users and interactivity
 - Earth observation data will be used to ensure model quality and quantify the uncertainties of impact assessments.
- Deployment on LUMI and MareNostrum 5

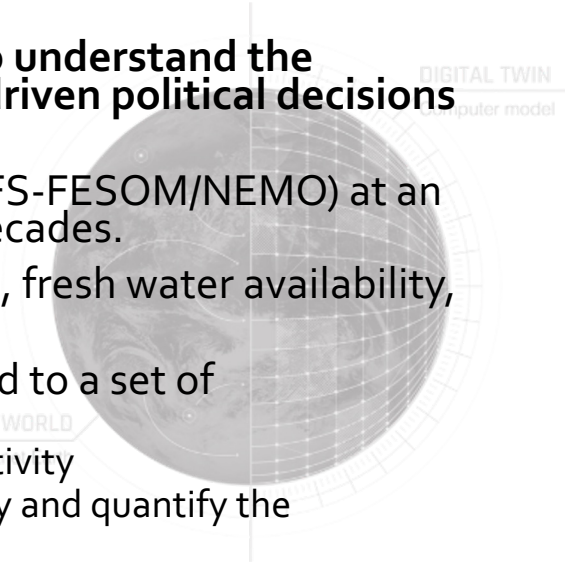

Global climate model ICON performance on LUMI-G

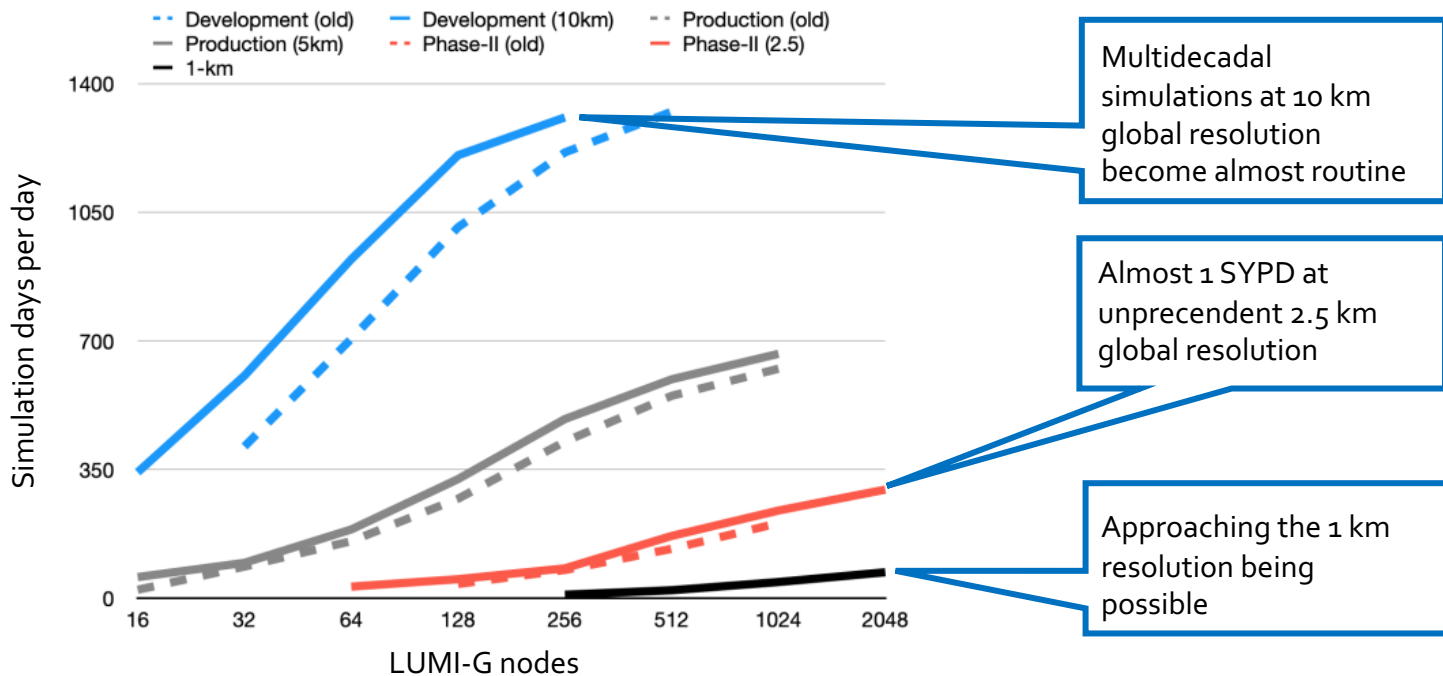

Early Showcases: Solar Astrophysics

- **Objective:** Understand subsurface solar physics to improve forecasting of solar storms and therefore space weather
- LUMI pilot project verified the existence of the fluctuating dynamo mechanism in the Sun

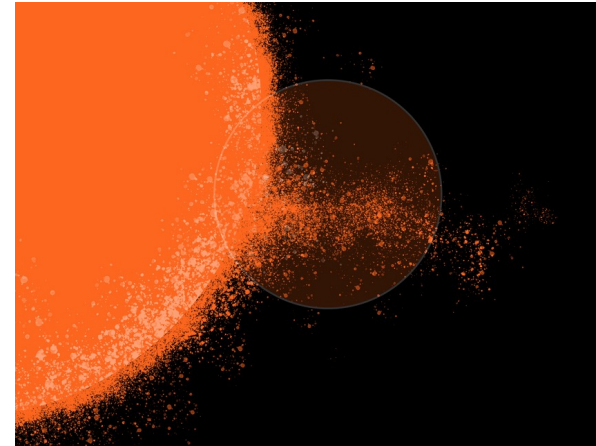

<https://www.lumi-supercomputer.eu/researchers-discovered-information-from-under-the-suns-surface-about-the-emergence-of-solar-storms-using-the-lumi-supercomputer/>

Early Showcases: Turbulent Dynamics in Superfluid Fermi Systems

- Fermionic superfluids important in e.g. understanding neutron stars
- To model a fermion superfluid, one needs to track all quantum states
- A pilot project on LUMI performed eigenvalue problem solutions with matrix sizes of 3M
 - the largest direct eigenvalue solution to date

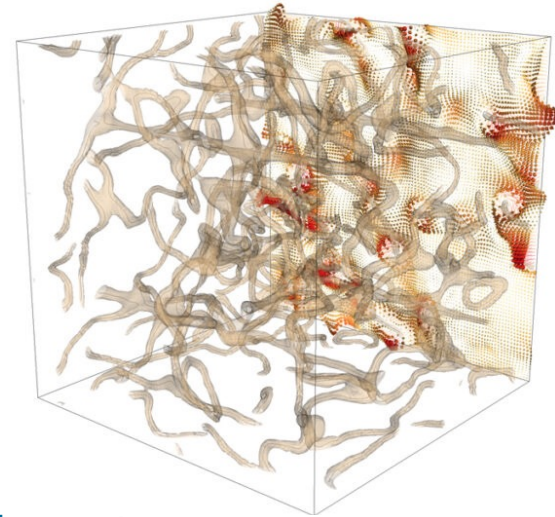

<https://www.lumi-supercomputer.eu/successful-polish-lumi-pilot-project-in-the-field-of-quantum-mechanics/>

Early Showcases: Extreme-scale high-fidelity turbulence simulations of convection

- Objective: High-fidelity Spectral-Element simulations for turbulence
- Rayleigh-Bénard canonical turbulent convection at extreme scale

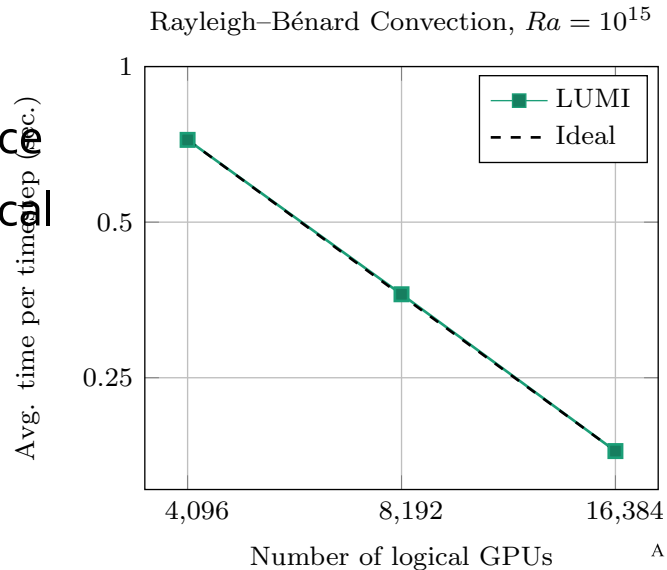

Cooled wall

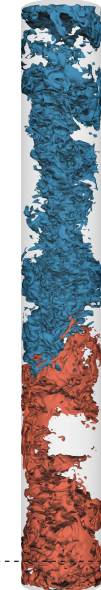

Heated wall

Cross-section AA. Velocity magnitude

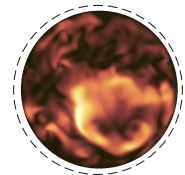

Cross-section AA. Temperature

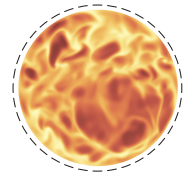

Gordon-Bell Prize 2023 finalist

<https://sc23.supercomputing.org/2023/08/a-look-at-the-2023-gordon-bell-prize-finalists/>

Concluding remarks



New golden era in European HPC under the leadership of EuroHPC Joint Undertaking



LUMI, the Queen of the North: leadership-class resource designed for a broad range of user communities and workloads, with an enhanced user experience

In full customer use since December 2022



LUMI's capabilities already in use for societally important science initiatives - cracking previously intractable computing problems, every day!

LUMI



Dr. Pekka Manninen

Director, Science & Technology

CSC – IT Center for Science

pekka.manninen@csc.fi

Follow us

Twitter: @LUMIhpc

LinkedIn: LUMI supercomputer

YouTube: LUMI supercomputer

www.lumi-supercomputer.eu



EuroHPC
Joint Undertaking



The acquisition and operation of the EuroHPC supercomputer is funded jointly by the EuroHPC Joint Undertaking, through the European Union's Connecting Europe Facility and the Horizon 2020 research and innovation programme, as well as the of Participating States FI, BE, CH, CZ, DK, EE, IS, NO, PL, SE.

Leverage from
the EU
2014–2020



Kainuun liitto